

1 Colorie le dessin si le trait en pointillés est un axe de symétrie.

J'ai tracé l'axe de symétrie de ce dessin en pointillé.

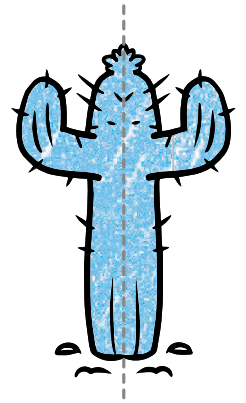

2 Repasse en rouge l'axe de symétrie.

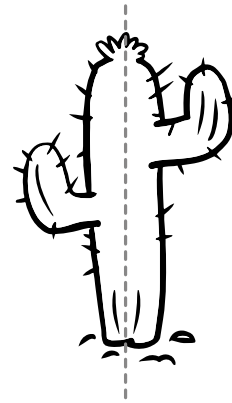
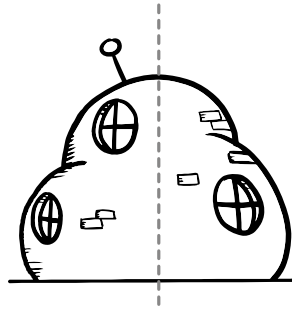
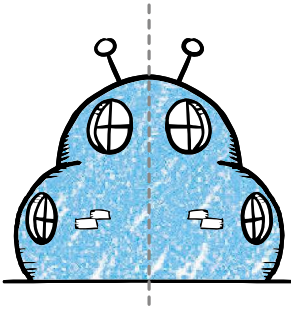
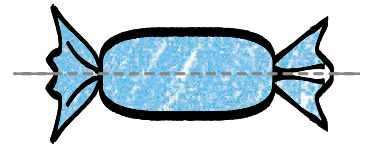
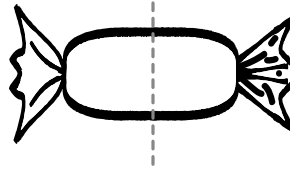
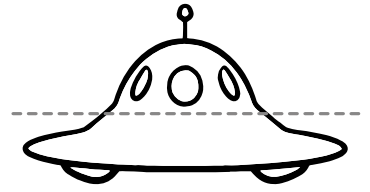
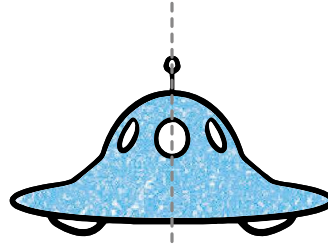
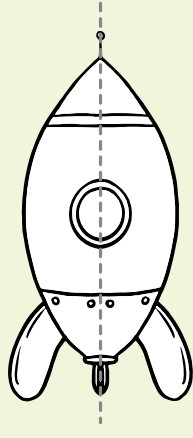
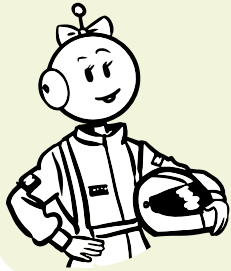
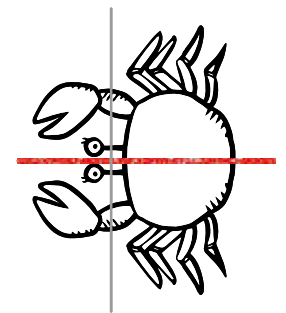
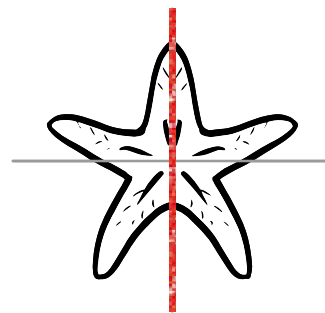
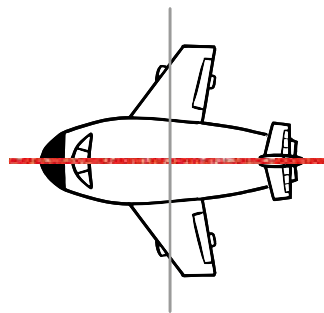
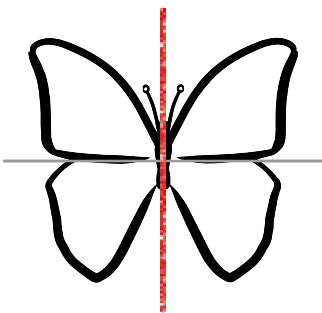

3 Repasse en rouge l'axe de symétrie.

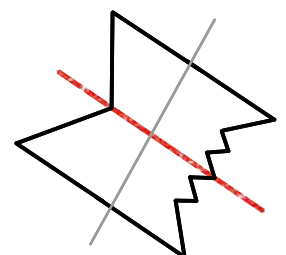
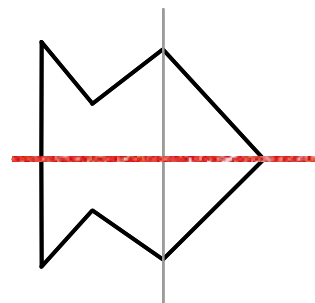
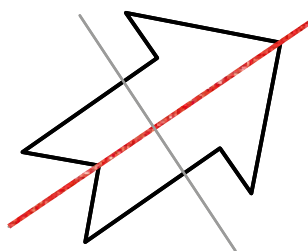
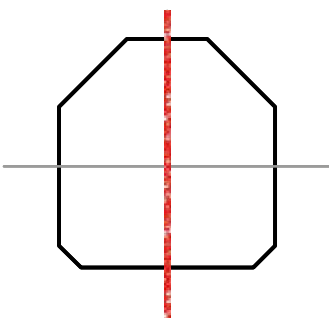

1 Trace en rouge l'axe de symétrie de chaque dessin.

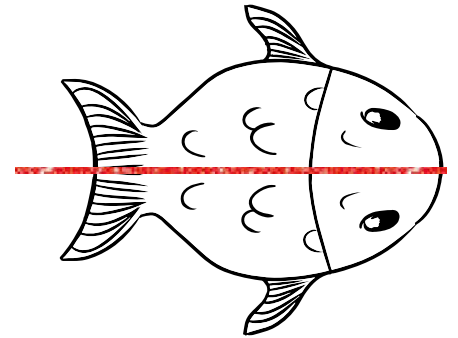
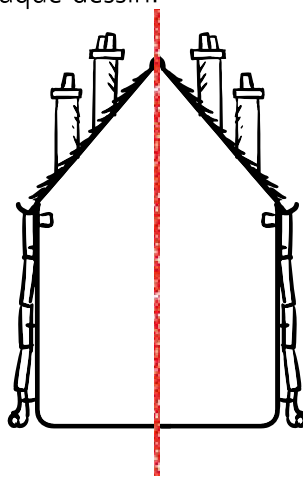
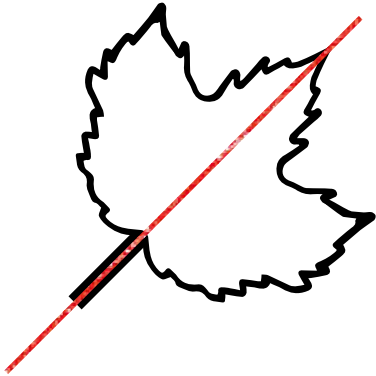

2 Trace en rouge le (ou les) axe(s) de symétrie de chaque figure.

Attention !  
Certaines figures peuvent  
avoir plusieurs axes  
de symétrie.

